

SLIDE GATE

| CODING | | | | CHARACTERISTICS | | | | | | | | | |
|--------------|------|--|---|-------------------|------------|-----|-----|-----|-----|------|------|------|-----|
| Machine Code | Size | Orientation (Vertical / Horizontal Dx o Sx Flow behind) | Actuator (Manual / Pneumatic / Electric) | Weights* (Kg.) | DIMENSIONS | | | | | | | | |
| | | | | | A | A1 | B | B1 | C | D | E | F | H |
| VG | 200 | VV | M | 30 | 194 | 174 | 355 | 345 | 294 | 530 | 1060 | 1231 | 100 |
| | | OD | P | | 194 | 184 | 355 | 335 | 294 | 530 | 659 | 830 | 100 |
| | | OS | E | | | | | | | | | | |
| | 250 | VV | M | 37 | 244 | 224 | 355 | 345 | 344 | 530 | 1060 | 1231 | 100 |
| | | OD | P | | 244 | 234 | 355 | 335 | 344 | 530 | 759 | 930 | 100 |
| | | OS | E | | | | | | | | | | |
| | 300 | VV | M | 42 | 294 | 274 | 355 | 345 | 394 | 530 | 1060 | 1231 | 100 |
| | | OD | P | | 294 | 284 | 355 | 335 | 394 | 530 | 820 | 991 | 100 |
| | | OS | E | | | | | | | | | | |
| | 350 | VV | M | 46 | 344 | 324 | 355 | 345 | 444 | 530 | 1060 | 1231 | 100 |
| | | OD | P | | 344 | 334 | 355 | 335 | 444 | 530 | 920 | 1091 | 100 |
| | | OS | E | | | | | | | | | | |
| | 400 | VV | M | 49 | 394 | 374 | 355 | 345 | 494 | 530 | 1060 | 1231 | 100 |
| | | OD | P | | 394 | 384 | 355 | 335 | 494 | 530 | 1020 | 1191 | 100 |
| | | OS | E | | | | | | | | | | |
| | 450 | VV | M | 51 | 444 | 424 | 355 | 345 | 544 | 530 | 1060 | 1231 | 100 |
| | | OD | P | | 444 | 434 | 355 | 335 | 544 | 530 | 1120 | 1291 | 100 |
| | | OS | E | | | | | | | | | | |
| 500 | VV | M | 54 | 494 | 474 | 355 | 345 | 694 | 530 | 1060 | 1231 | 100 | |
| | OD | P | | 494 | 484 | 355 | 335 | 694 | 530 | 1220 | 1391 | 100 | |
| | OS | E | | | | | | | | | | | |

*indicative

Horizontal orientation

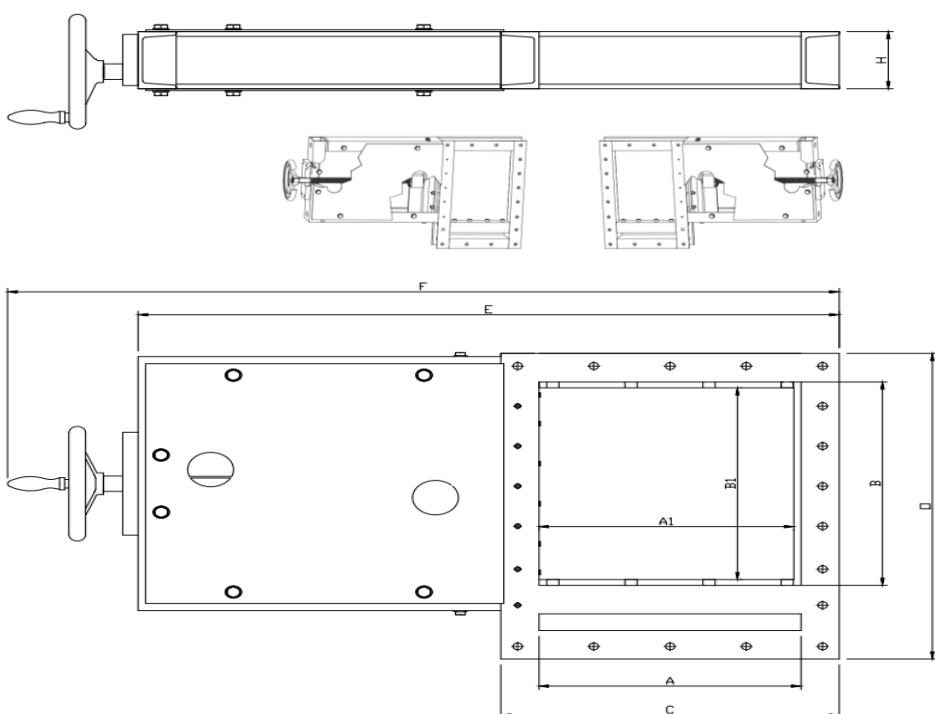

Vertical orientation

